

Halley's BlueTM

Built for Life
Pre-Engineered Buildings

A Structural Steel Construction Company - Since 1993

1000+ Projects | 2.0 Crore Sq. ft Completed

Design | Analysis | Fabrication | Supply | Installation | Exports



Our Vision:

- To be the most Innovative & Reliable Company for each and every customer, no matter how small, delivering the best & optimum building solutions.
- To not only deliver the highest-quality & stable buildings to our customers, but also educate them about the building design, stability criteria, quality of each material we use & our standard Stringent Quality Policies.
- To guarantee our continued success & achieve leadership in our industry through individual and combined dedication, innovation & integrity.
- To give our employees the opportunity for both personal and professional growth.
- To develop and maintain our supplier/customer relationship based on open communication, mutual trust and respect.
- To follow standard industrial safety practices at every step, everyday & everywhere.

Chairman's Note

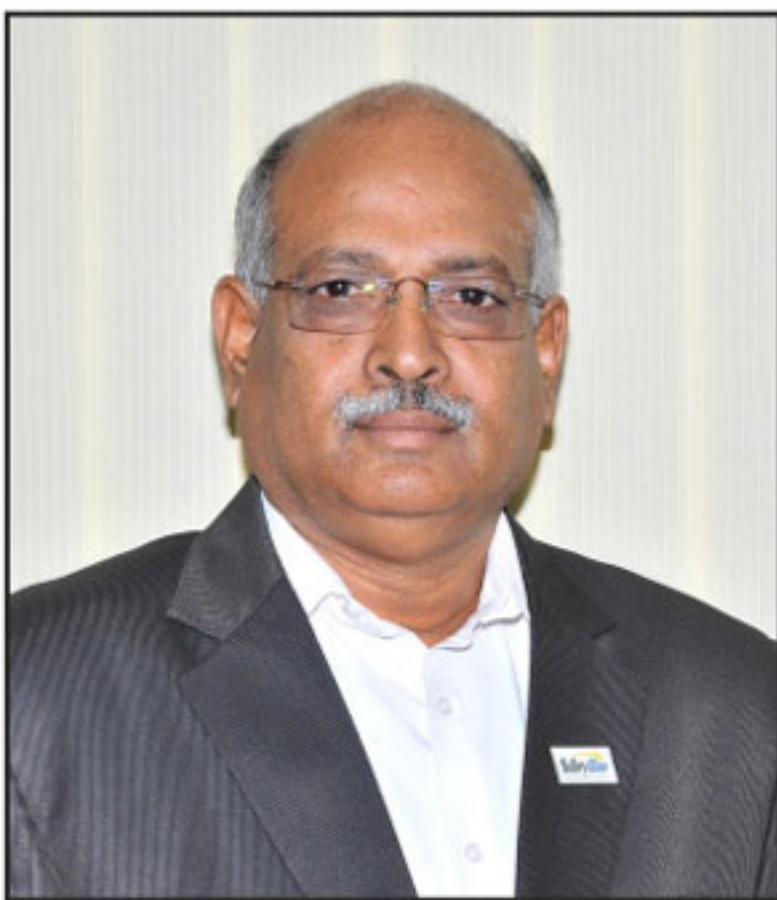

Shiva Murthy K.M.
Founder & Chairman

Having extensive experience in Middle East & an Engineer by profession, my major focus & consideration is towards every customer's satisfaction with our product. I see every Structure we make at Halley's Blue as a monument & emphasize on quality workmanship at every level without any compromise or deviations. My team of 450+ employee is equally driven with passion towards construction of Quality, Premium & Elite Pre Engineered Buildings across India & other countries.

Our Awards & Accolades



KASSIA Utpadana Uthkrushta Prashasti 2015



Successful Entrepreneur of Bellary District 2012



Sir M. Visvesvaraya Manufacturing Excellence Award 2017



Vanija Ratna Award 2018



Ujwala Udhya Prashasti 2018

1.0 About Us

HalleysBlue Steels Pvt Ltd., - A Structural Steel Fabrication Company started in 1993 with a commitment & vision to emerge globally as most trusted & committed metal building solutions company. HalleysBlue caters India & African countries. We have successfully completed more than 1000+ projects - 20 Million Sq. ft with appreciation from every client transforming from structural steel fabrication company to Design, Analysis, Manufacturing, Supply & Installation organisation.

Driven by highest quality principals, complete safety standards & ethical business practices, we are the company with inherent passion & commitment towards Steel Building construction.

At HalleysBlue, we just don't find customers for our products, we benchmark customer's actual requirement & we engineer, develop & offer refined & optimum building solutions.

1.1 Why Us ?

It is quite obvious question that you have before choosing us as your builder. With immense pleasure & pride, we let you know that we have successfully completed 1000+ projects - 20 Million Sq. ft across India & Africa. All our clients are very much satisfied & have supported us along the journey since 1993.

In addition to the above, following are the points we are saliently different.

- One point sourcing Steel & Civil part (Design & Execution).
- Complete transparency in Design & Quantities.
- 100% vetted Designs.
- International quality standards at every step.
- TSP (Total Safety Practice) is our prime motto.
- Highest focus & prime criteria towards optimization of design.
- Dedicated & committed working team.
- Immediate response with high speed & eminently decision making authorities.
- Continuous improvement/research/optimization over Design part.
- Acceptance of any challenging & time bound projects.
- Adaptability towards new concepts.



2.0 Plant & Infra

- Total Area: 125000 Sq. Ft.
- Covered Area: 60000 Sq. Ft.
- Number of Modules: 3
- Production Capacity: 20000 Mt per Annum.



2.1 Module 1:

- Raw Material Storage
- Capacity to store upto 1500 Mt.
- Hydraulic Shearing
- For accurate & paper cut quality.
- CNC Punching - Automatic
- For accurate & fast punching.
- Primary Beam Fit Up
- Complete auto type with fool proof weld quality.

2.2 Module 2 & 2A:

- H Beam Welding Line
- Twin wire, Sub - Arc welding concept.
- Accessories Fit Up
- Accurate positioning ensuring actual Design strength.
- Full Welding
As per American Welding Standards.

2.3 Module 3:

- Cold Form Section Lines (C & Z)
- Secondary sections for secondary framing.
- Sheeting Line
- Complete sheet range products line.
- CNC Press Brake
- Trims & Flashing Forming.
- CNC Crimping
- Curved eaves for special Aesthetics purpose.



3.1 CNC Plasma Cutting: ■ Size: 4.0 m x 18.0 m.

3.2 Shearing Machine: ■ Size: 6.3 m max cut length.
■ Thickness: 15.0 mm max.



3.3 H Beam Fit Up Machine: ■ Size: 1.5 m max width x 15.0 m max length.

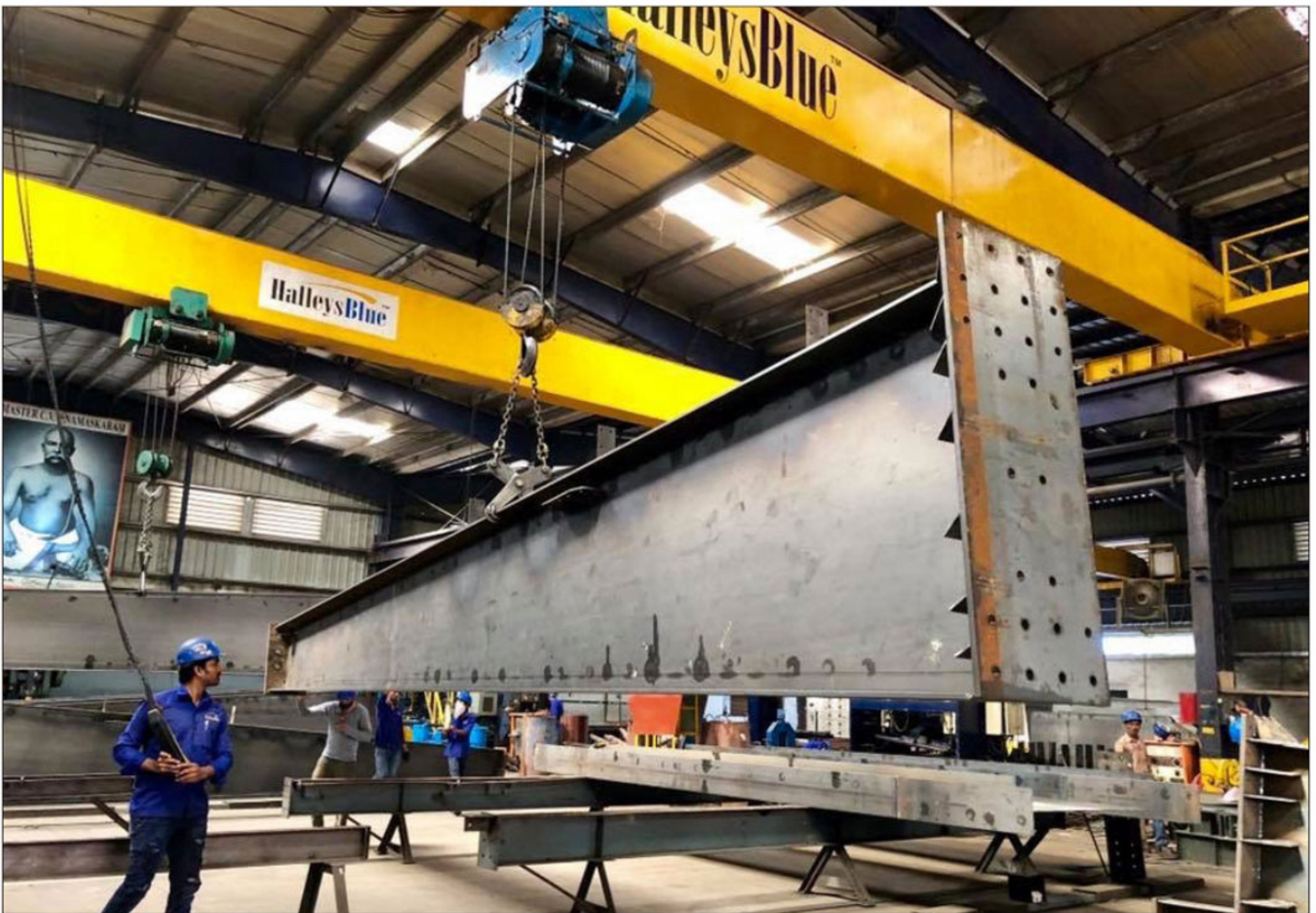

3.4 MIG Welding Line (Flux Cored):



3.5 Loaded Truck:



4.1 C & Z Section (Cold Form) Line:

- Independent C & Z form profiling line with dedicated de-coilers & control systems ensuring fast & accurate forming process.



4.2 Z Purlin Line:

- Type: Pre Punch, Post cutting type & complete automatic.
- Machine Capacity: 1000 Mt per month.
- Sizes: 180 x 60 x 20 mm
 - 200 x 60 x 20 mm
 - 230 x 60 x 20 mm
 - 250 x 60 x 20 mm
- Thickness: 1.0 mm to 3.5 mm



4.3 C Purlin Line:

- Type: Pre Punch, Post cutting type & complete automatic.
- Machine Capacity: 1000 Mt per month.
- Sizes: 180 x 60 x 20 mm
 - 200 x 60 x 20 mm
 - 230 x 60 x 20 mm
 - 250 x 60 x 20 mm
- Thickness: 1.0 mm to 3.5 mm



5.1 Sheeting, Crimping & Flashings Line:



5.2 Sheeting Line:

- Type: 22 Stages - Rollers, Post & Pre Cutting.
- Complete automatic type.
- Capacity: 1000 Mt per month.
- Thickness: 0.2 mm to 0.8 mm.

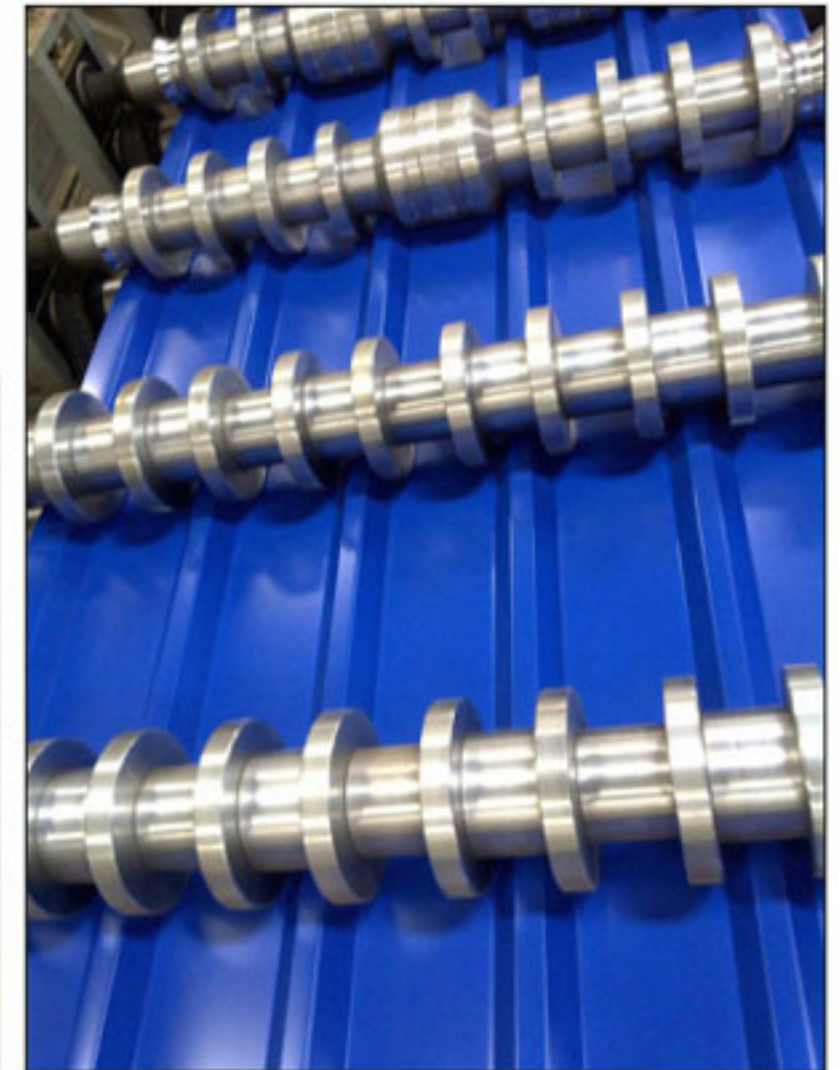

5.3 CNC Press Brake:

- Type: CNC Automatic 6.3m long Hydraulic Press Brake.
- Thickness: 0.2 mm to 2.0 mm.



5.4 Crimping Line:

- Type: Automatic Hydraulic Crimping.
- Capacity: 50 Mt per month.
- Thickness: 0.2 mm to 0.8 mm.



6.0 Products:

6.1 a. Pre Engineered Building Systems (PEB):

Halley's Blue Pre Engineered Buildings are pre designed, fabricated & erected matching exact customer's requirement satisfying all the aspects involved, ensuring it serves to best of its design extent.

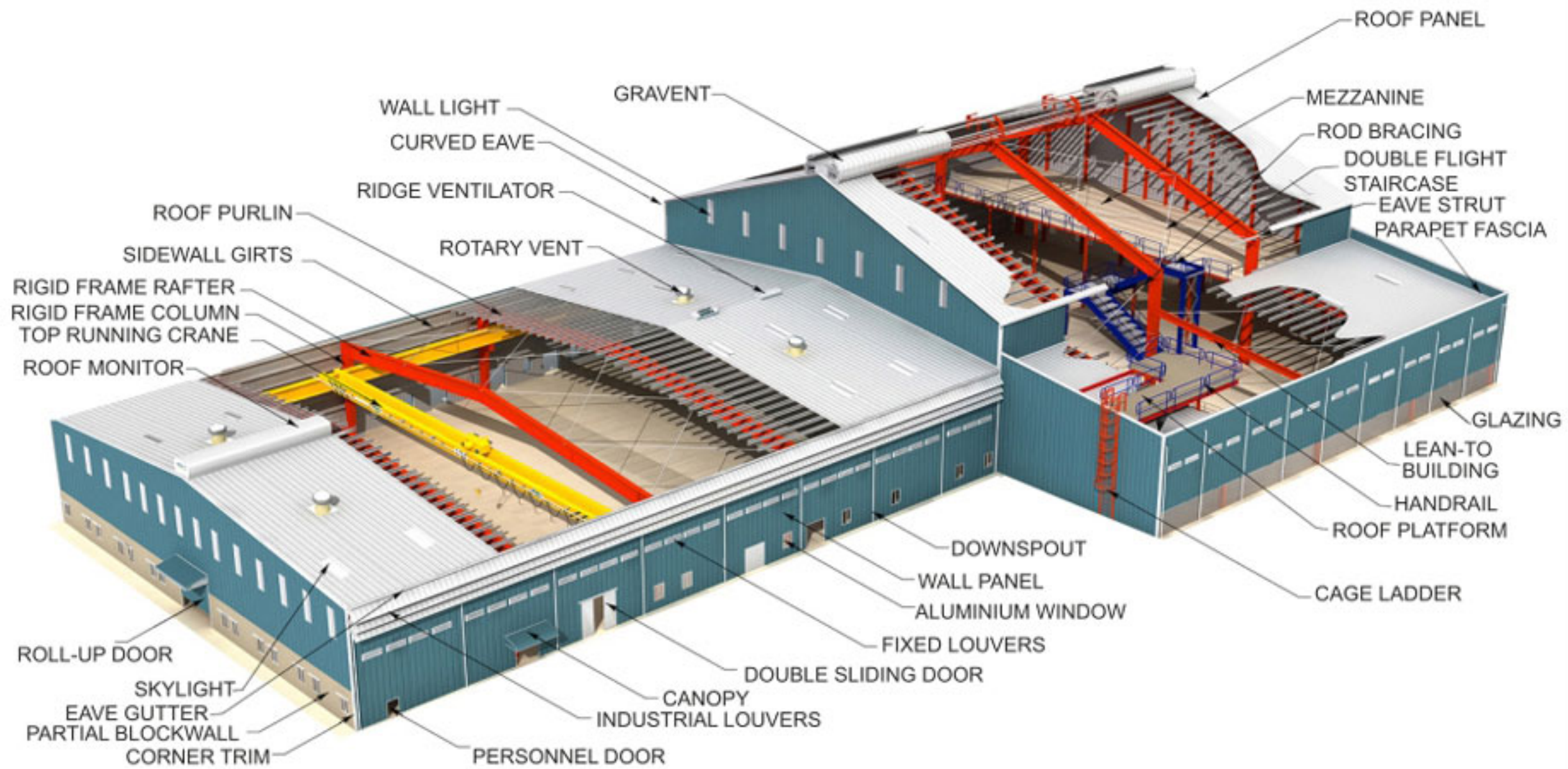

India is one of the fastest growing countries with macro level industrialization contributing to its economy. PEB holds 56% share of market construction regardless of type of Industry.

6.2 Applications of Pre Engineered Buildings

Industrial	Institutional	Commercial	Heavy Industrial
Factories	Schools	Showrooms	Steel Rolling Mills
Workshops	Convention Halls	Supermarkets	Power Plants
Warehouses	Hospitals	Restaurants	Cement Industries
Cold Stores	Theatres	Offices	Textile Mills
Car Parking Sheds	Auditoriums	Service Stations	Food Processing Industries
Bulk Product Warehouse	Sports Complex	Shopping Malls	Automobile Industries

Recreational	Aviation & Military	Agricultural	Residential
Gymnasiums	Aircraft Hangers	Poultry / Dairy Farms	Single/Multi Storied Buildings
Swimming Pool Enclosures	Administration Buildings	Greenhouses	Mega Apartments
Indoor Tennis / Badminton	Residential Barracks	Grain Storage	Villas
Squash Courts	Support Facilities		Ready to use Labor Quarters

7.0 PEB Options

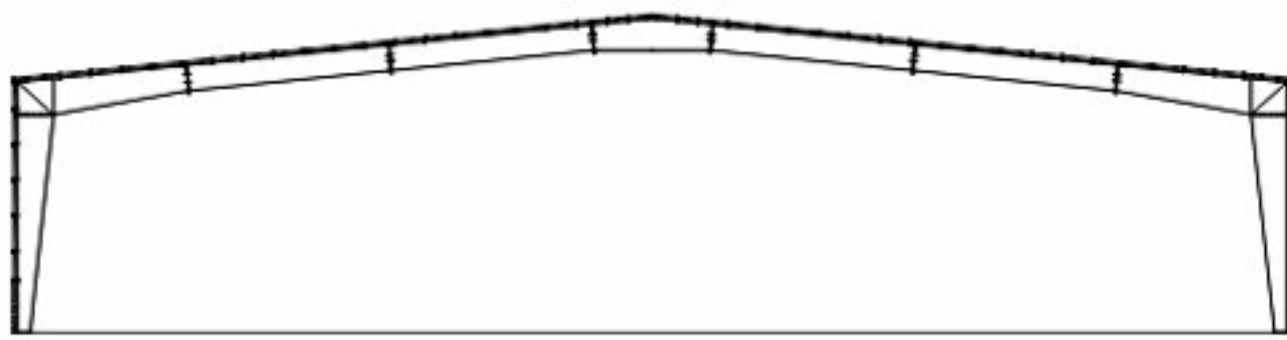

DOUBLE SLOPE - RF (CLEAR SPAN)

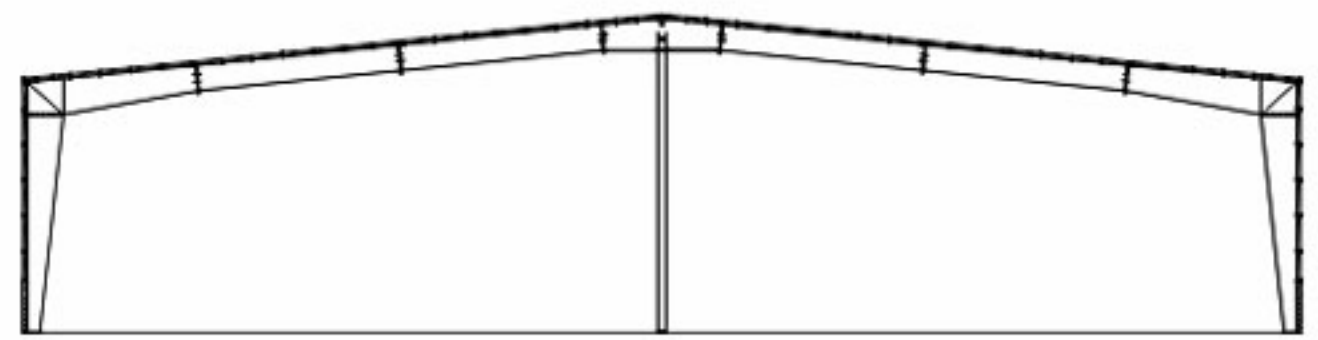

DOUBLE SLOPE - LRFM 1

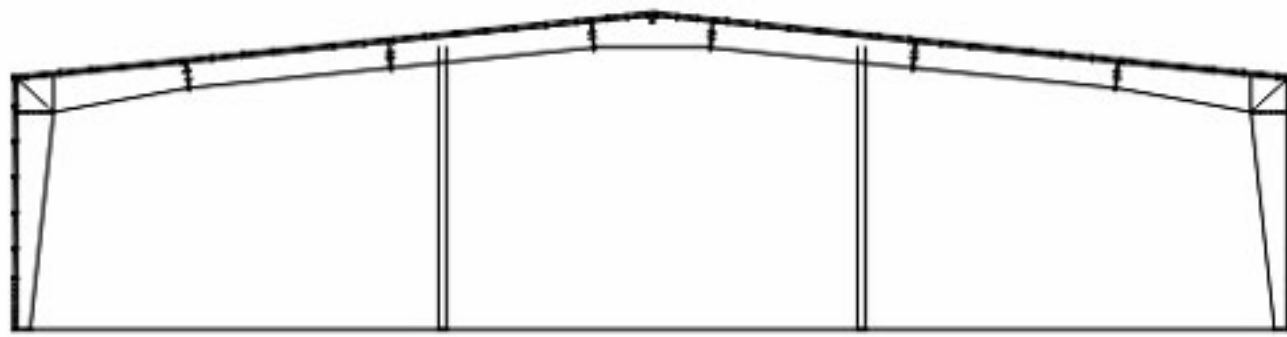

DOUBLE SLOPE - LRFM 2

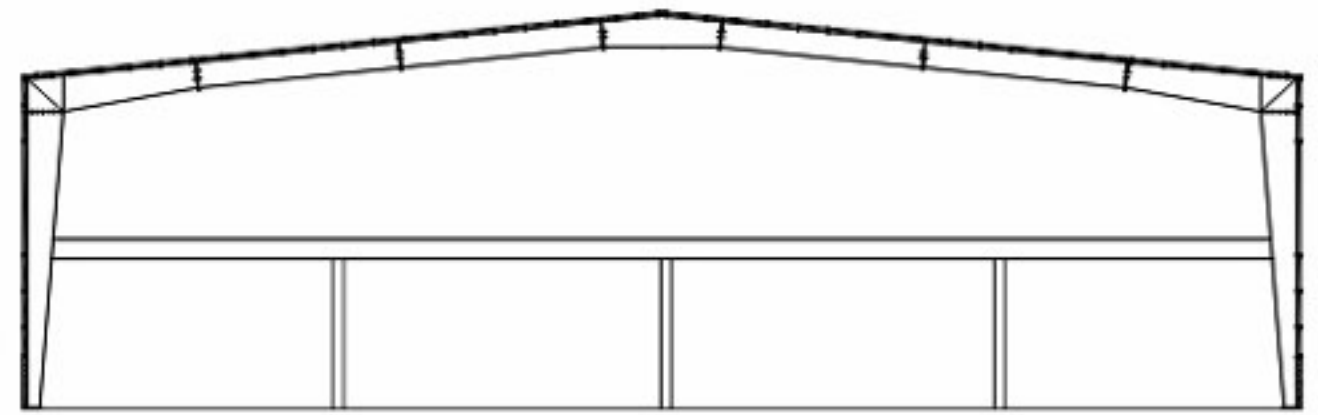

DOUBLE SLOPE - WITH MEZZANINE

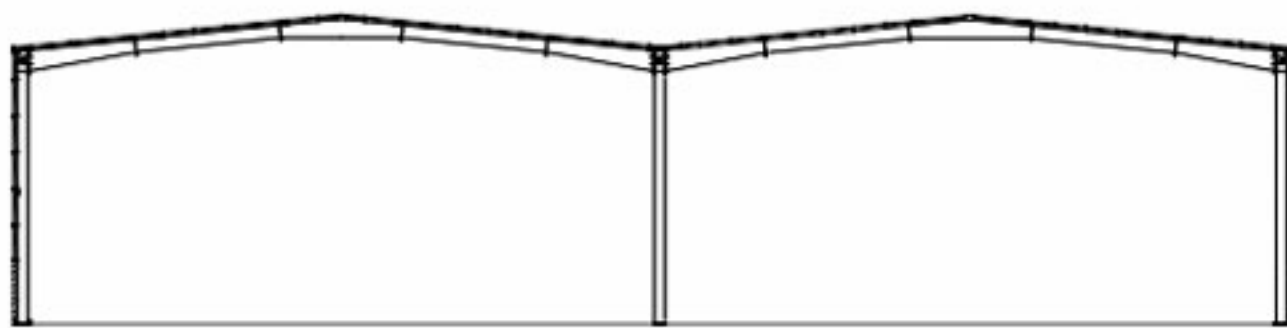

DOUBLE SLOPE - MULTI GABLE

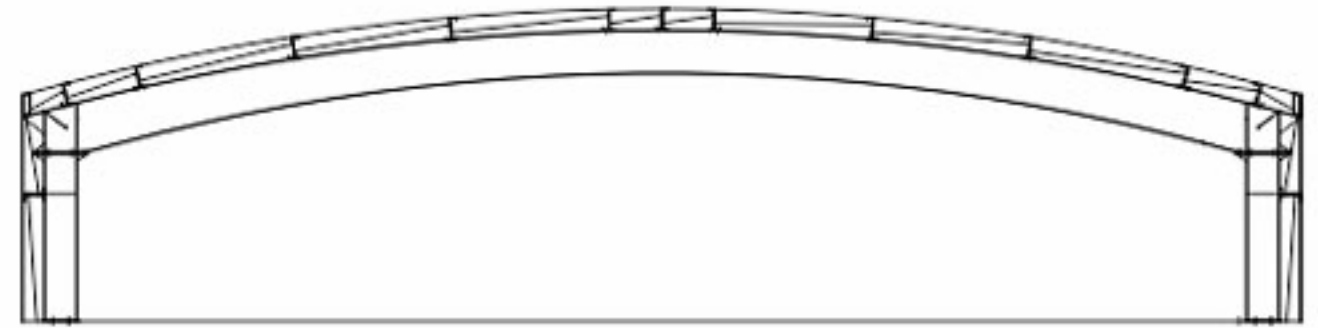

CURVE ROOF - RF (CLEAR SPAN)

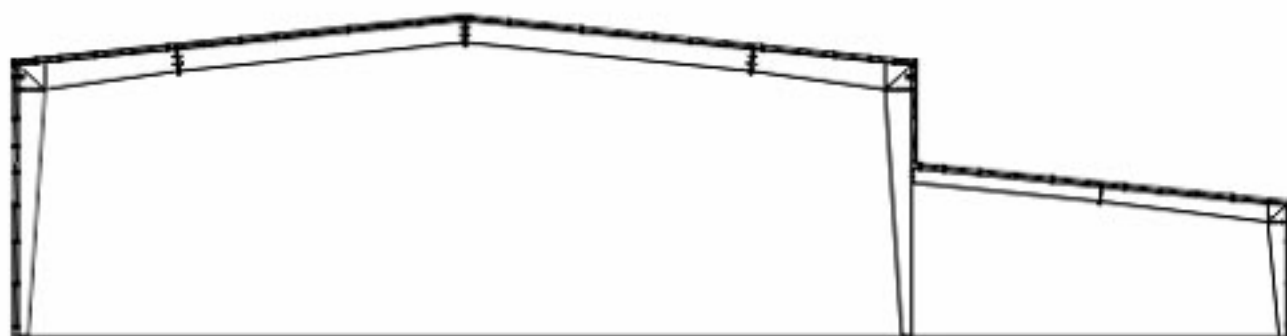

DOUBLE SLOPE WITH LEAN TO

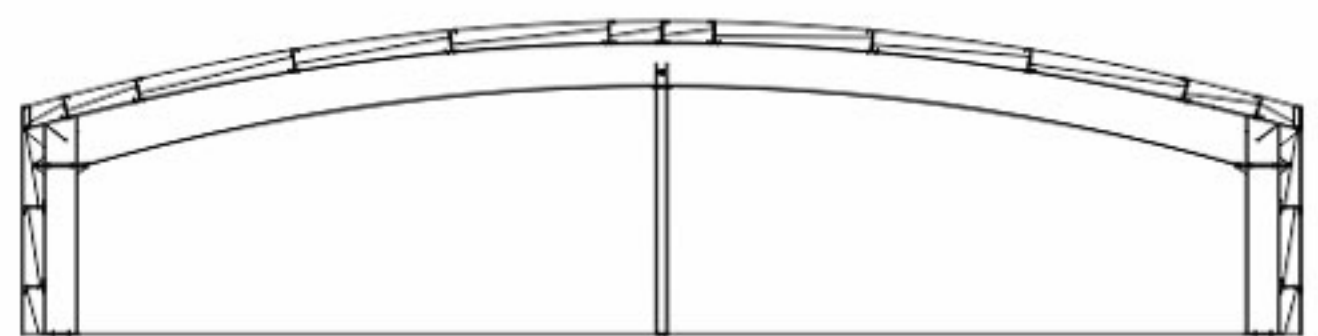

CURVE ROOF - LRFM 1

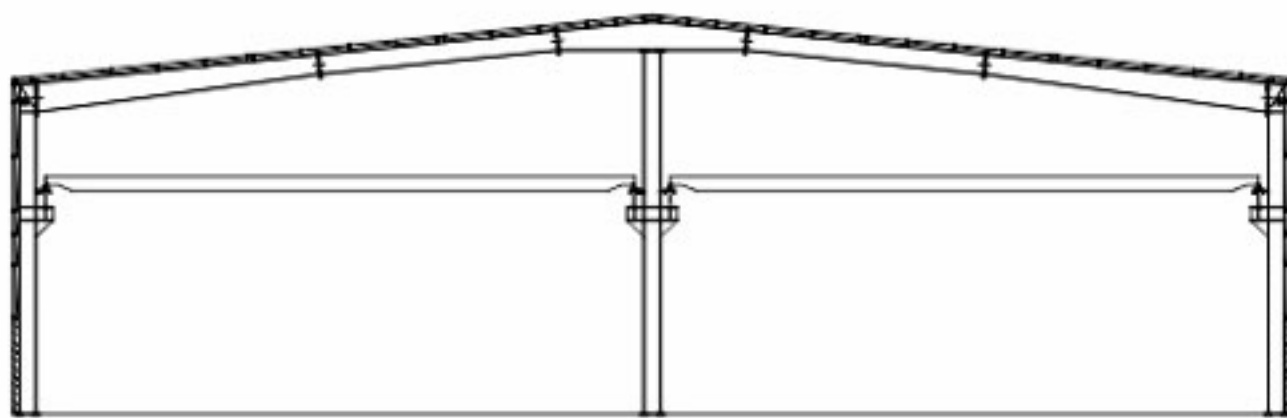

DOUBLE SLOPE WITH EOT CRANE



SINGLE SLOPE - RF (CLEAR SPAN)

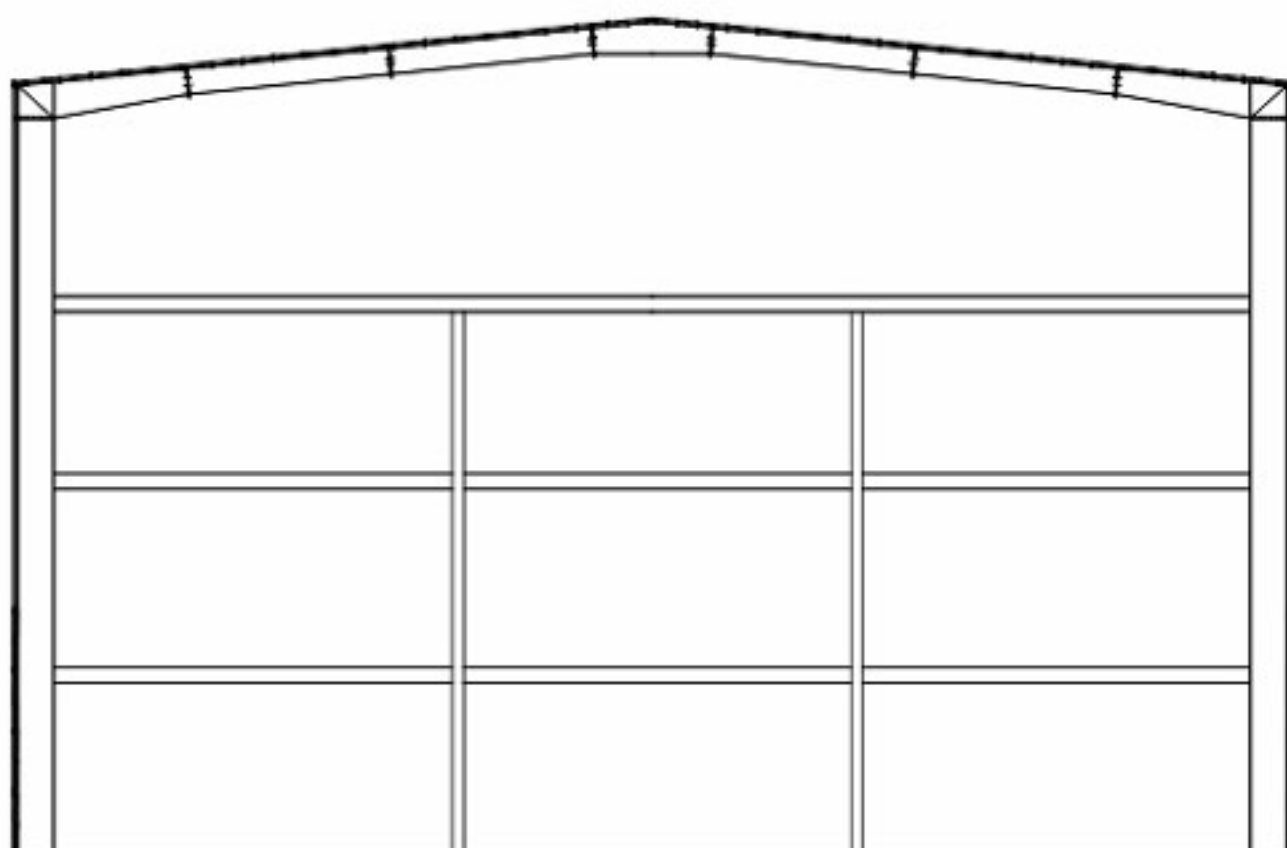

MULTI LEVEL MEZZANINE

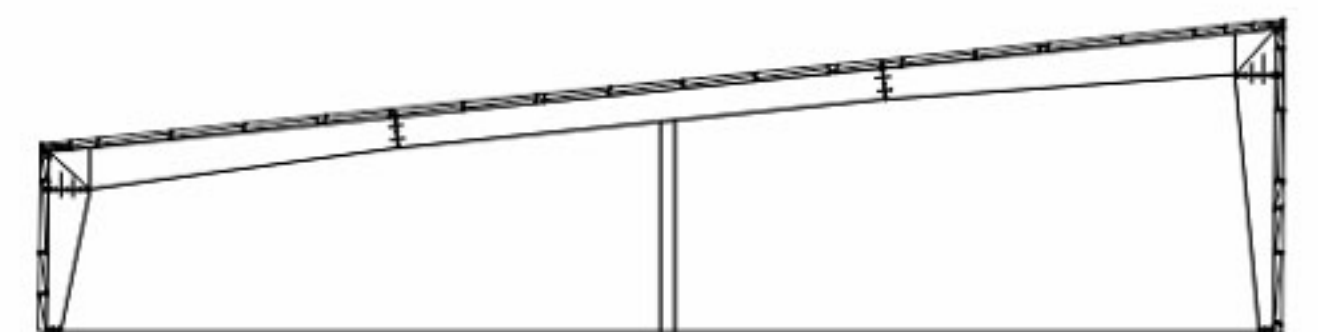

SINGLE SLOPE - LRFM 1



SINGLE SLOPE - LRFM 2

8.0 Pre Engineered Building Vs. Conventional Steel Building (Comparison)

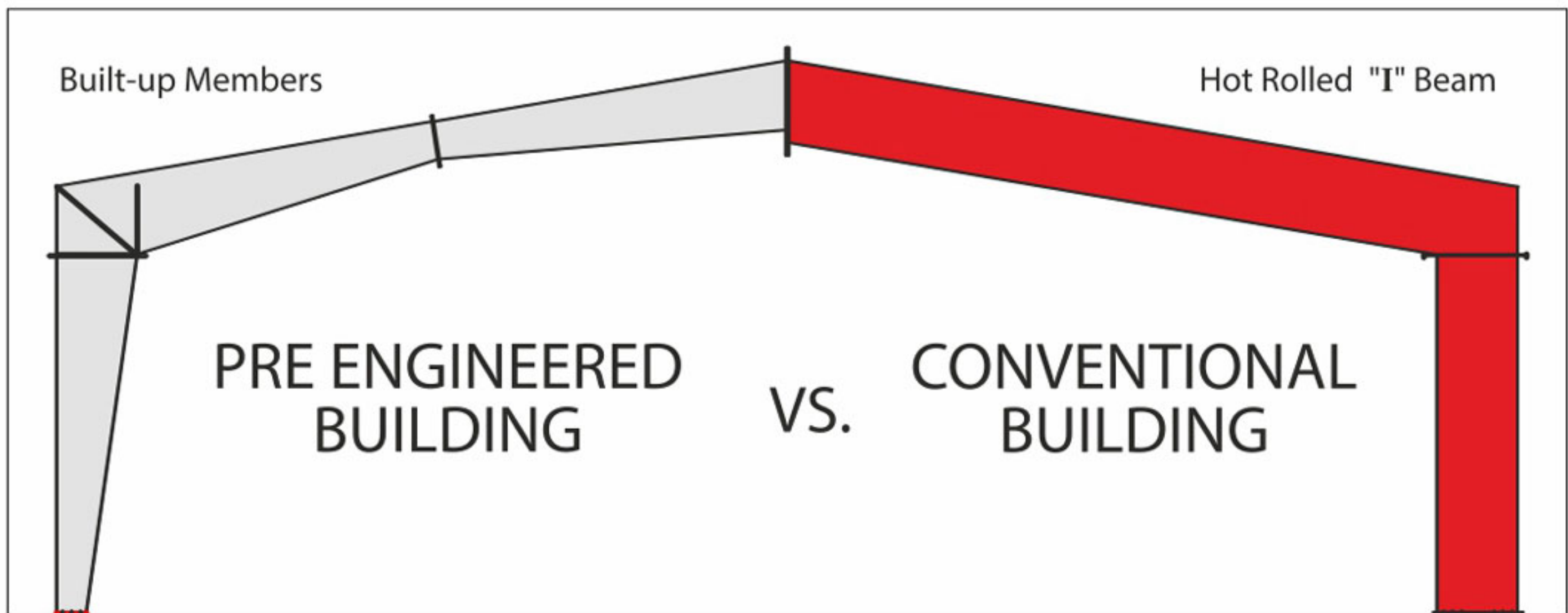

Parameter	Pre Engineered Building	Conventional Steel Building
Structure Weight	PEB's are average 30% lighter through optimized design by tapered (varying depth) built-up sections with higher depths in the areas of highest stress.	Steel members are selected from standard hot rolled "I" Sections, which are heavier than what is actually required by design as the members have constant cross-sections regardless of varying magnitude of the local (internal) stress along the member length.
Steel Strength	High Tensile Steel used in PEB's having minimum (Ys) of 345 Mpa, which contributes to reduction of Steel consumption in overall.	Conventional "I" & "C" sections usually have minimum (Ys) of 245 Mpa, resulting in higher Steel consumption.
Design Speed	Design of PEB's is quick & efficient as the design process involve special dedicated international design software, international design codes & standard sections & connections.	The Design Consultant, resulting in excess design time with fewer design aids available to the Engineer, designs each conventional Steel structure from scratch. Generalized computer analysis programs require extensive input/output and design alterations.
Clear Spans	PEB's can be designed & erected with max clear span of 100 m. with low steel qty. consumption.	Conventional building can be for max 40 m. with high steel qty. consumption.
Civil Foundations	Simple & economical with larger span & higher column spacing, resulting in less number of foundations along length & width.	Extremely heavier footings & more number of footing because of constraints line lower column spacing & supports along width wise.
Erection Speed	Since the connections of the components are standard, the learning curve of erection for each subsequent project is faster.	The connections are normally complicated and differ from project to project, resulting in longer learning curves of erection for new projects.
Seismic Resistance	The low-weight flexible frames offer higher resistance to seismic forces.	Rigid heavy weight structures do not perform well in seismic zones.
Safety & Responsibility	Single source of supply results in total responsibility by one supplier, including design liability. PEB manufacturers can be relied upon to service their buildings, long after they are supplied, to protect their reputation.	Multiple responsibilities can result in questions on who is responsible when components do not fit properly, insufficient material is supplied, or materials fail to perform, particularly at the supplier/contractor interface. The consultant carries total design liability.
Performance	All components have been specified and designed specifically to act together as a system for maximum efficiency, precise fit, and peak performance in the field.	Components are custom designed for a specific application on a specific job. Design and detailing errors are possible when assembling the diverse components into unique buildings.

9.0 Cold Rolled Sections (C & Z):

Cold Rolled (CR) Sections are advanced sections made of High Tensile Galvanized Steel in the thickness ranging from 1.0 mm to 3.0 mm in various depths as per design standards, suitable for different spans & loadings.

9.1 Sizes offered (C & Z Sections):

Web	Flange	Lip	Thickness
150	60	20	1.0 to 3.0
180	60	20	1.5 to 3.0
200	60	20	1.8 to 3.0
230	60	20	2.0 to 3.0
250	60	20	2.5 to 3.0
300	60	20	2.5 to 3.0

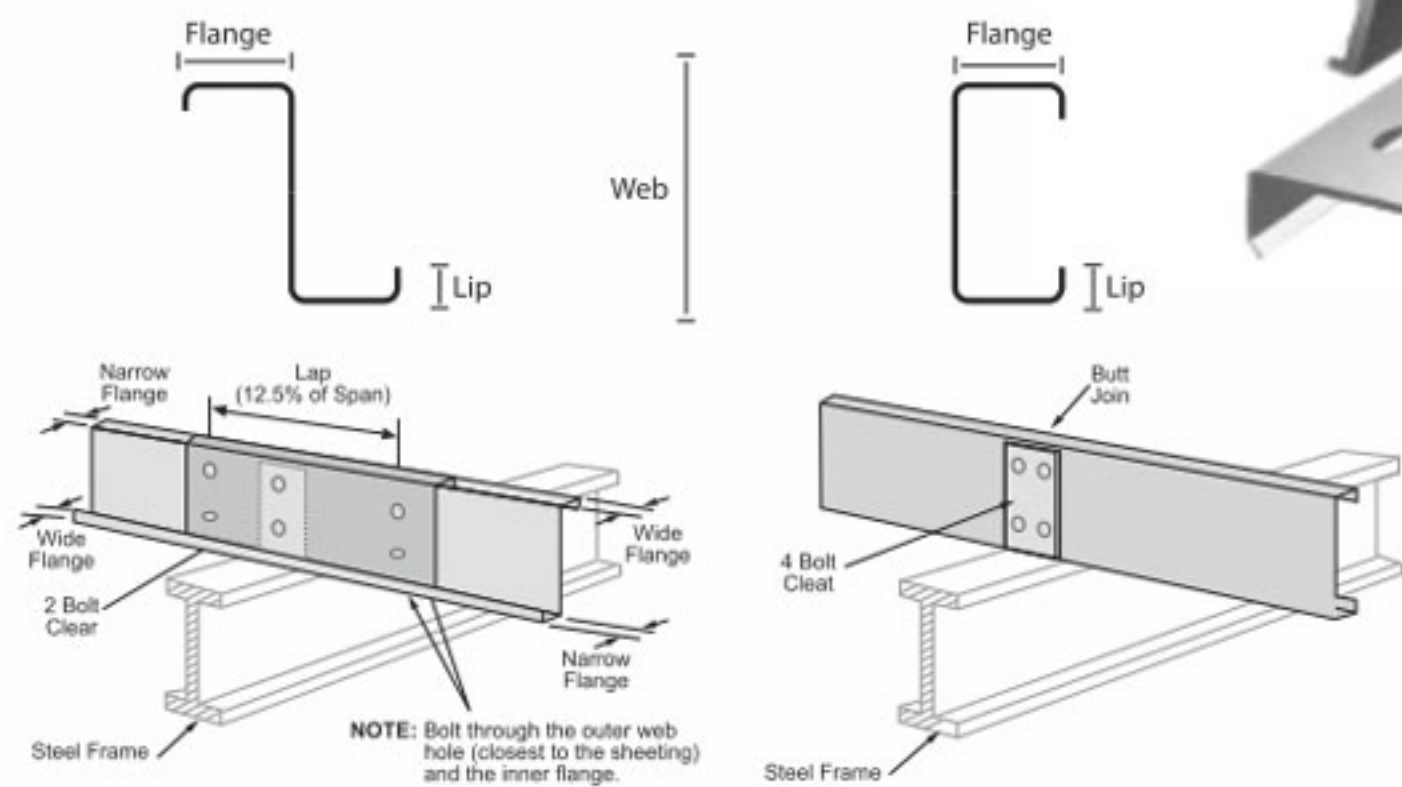

All dimension in mm

9.2 Color Coated Sheets:

Color Coated Profile Sheets are the profile sheets with the color coating over the metal surface after hot-dipped galvanized by Zinc. These profile sheets are manufactured by cold-rolling technique. Thickness of the colors coated on the surface of these sheets depends on the specific requirements.

9.3 Color Coating Material: RMP, SMP & PVDF 2

9.3 Our Standard Sheet Profile: (Roof & Cladding)

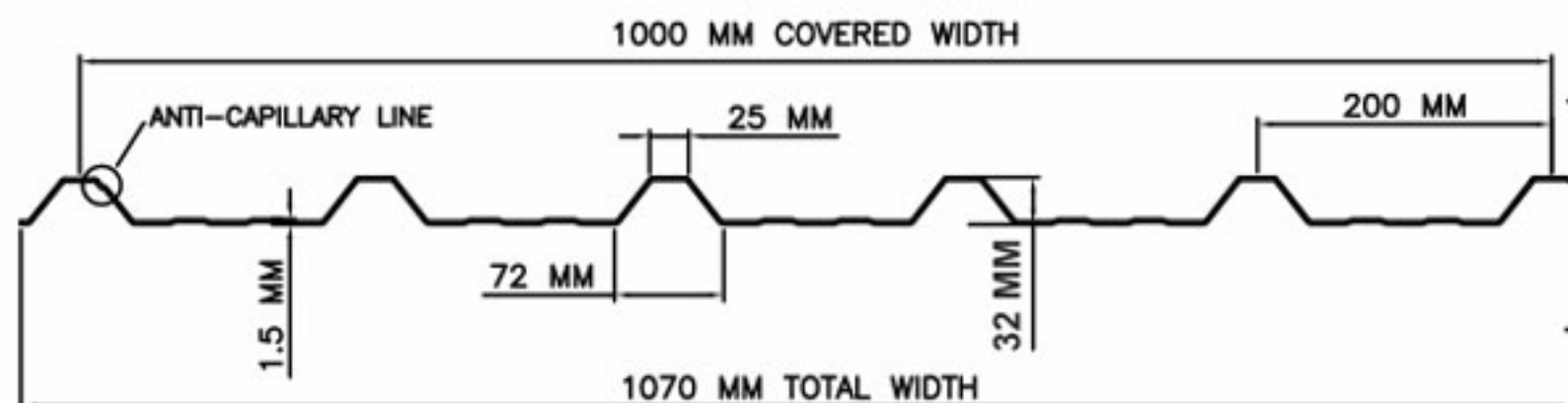

Sheet Specifications:

Guard Film	_____
Finish Coat	_____
Primer Coat	_____
Conversion Coat	_____
AZ Coat	_____
Base Steel	_____
AZ Coat	_____
Conversion Coat	_____
Primer	_____
Backer Coat	_____



9.4 Types of Sheet Material:

- Pre Painted Galvalume: CR Sheet with 150 GSM Al ZN coating & paint coating as per Std.
- Pre Painted Galvanized: CR Sheet with 120 GSM ZN coating & paint coating as per Std.
- Bare Galvalume: CR Sheet with 150 GSM Al ZN coating & no paint coating.

9.5 Sheet Thickness Offered: 0.35 mm, 0.4 mm, 0.42 mm, 0.47 mm, 0.5 mm, 0.6 mm & 0.8 mm.

9.6 Attributes:

- Dimensional accuracy.
- Light weight.
- Leak proof.
- Heat & water resistant.
- High strength.
- Corrosion resistant.
- Spectrum of colors.
- High durability.
- Multi coated.
- High impact strength.
- Good longevity.
- Economical on long run.

10.0 High Rise Steel Buildings:

HalleysBlue High Rise Steel Structures are made of Built-Up beams & Rolled Steel sections forming columns, joists, floor beams & roof Structure in the shape of the letter "I", Square & Star column sections. The two wide flanges of a column are thicker and are wider than the flanges on a beam, to better withstand compressive stress in the Structure. Steel beams are connected to the columns with bolts and threaded fasteners. The central "web" of the Steel I-beams is often wider than a column web to resist the higher bending moments that occur in beams.

Trapezoidal Steel deck panels can be used to cover the top of the Steel frame as a "form" or corrugated mould of thick layer of concrete and Steel reinforcing bars. Another popular alternative is a floor of precast concrete flooring units with some form of concrete topping. A form of raised flooring system provides the final floor surface with the void between the walking surface and the structural floor being used for cables and air handling ducts.

The exterior "skin" of our buildings is anchored to the frame using a variety of construction techniques and following a huge variety of architectural styles. Bricks, stone, reinforced concrete, architectural glass, sheet metal and simply paint have been used to cover the frame to protect the Steel from the weather.

10.1 Advantages of High Rise Steel Buildings:

- Cost Effective & Quick to Build.
- Strong & Design-Flexible.
- Higher & wider spans (column free wider spas).
- Durable & Safe.
- Environment Friendly.
- Fire Resistant.
- Earthquake Tested.

10.2 Applications of High Rise Steel Buildings:

- Shopping Malls.
- Hotels.
- Residential Apartments.
- Commercial Complex.
- Villas.
- Multi Level Car Parking.



11.0 Structural Fabrication:

Our Structural Fabrication division is headed by most experienced Structural Engineers with versatile knowledge in designing most Structural members employed in heavy Structural work & machine supporting Structures.

11.1 Verticals We Served:

- Steel Plants Sponge Iron & Pellet Plants.
- Power Plants.
- Slag Processing System.
- Food Processing Lines.
- Material Handling Systems.
- Mezzanine Structures.
- Access Systems for Tall Towers.
- Seed Drying Systems.
- Automatic Truck & Wagon Tilters.



12.0 Design:

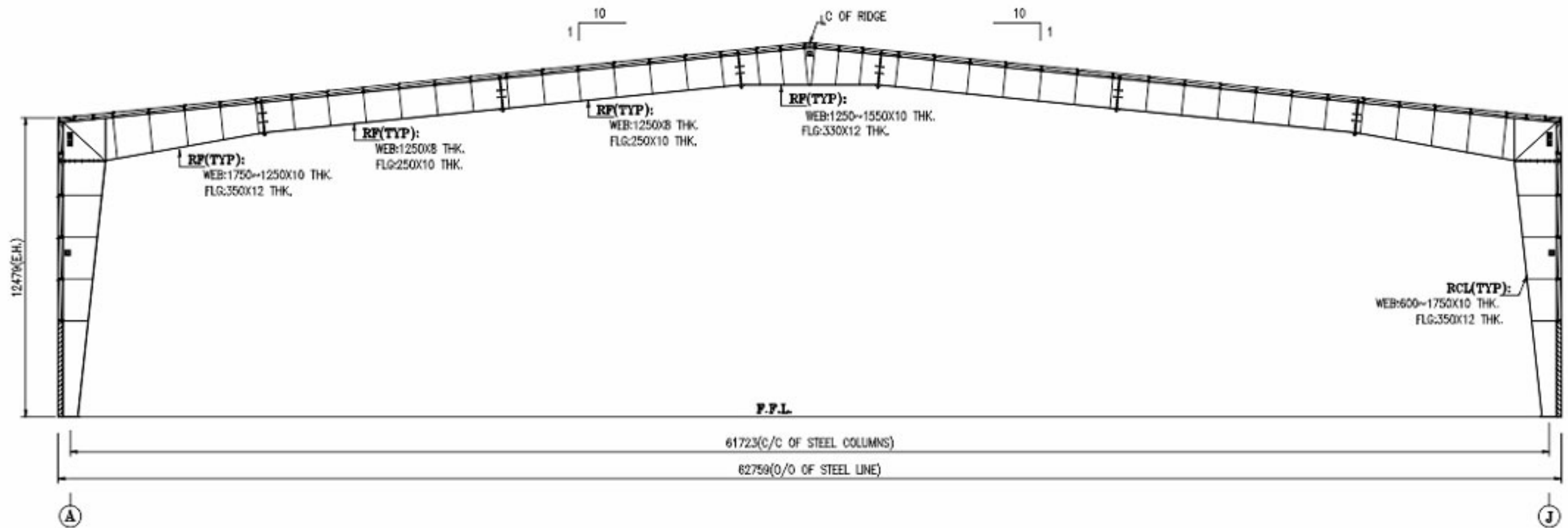

HalleysBlue Design team is headed by group of Senior Structural Engineers with 20+ years of experience & 15 Asst. Design Engineers. Our Structural design & detailing is extravagantly done with appropriate factor of safety inherent in itself capable of taking all the applicable building loads & impact loads. This special quality makes all our Structures very rigid against applicable dead load, live load, collateral & Seismic loads.

12.1 Design Software we use to Design your Building:

Staad.Pro



Loseke Technologies, Inc.
Serving the industry's software needs.



TEKLA



12.2 HalleysBlue Design Standards:

- A) AISC : American Institute of Steel Construction.
- B) AISI : American Iron and Steel Institute.
- C) MBMA : Metal Building Manufacturers Association.
- D) AWS : American Welding Society for Welding standards and Process.
- E) IS 875 Part 1~5 : General Loads & Wind load calculations and Applications in India.
- F) IS 1893 : Indian Code of Practice for Seismic Loads & Design.
- G) IS 816 : Indian Code for Welding Standards.
- H) IS 800-2007 : Indian Code of Practice for General Steel Construction.

13.0 Quality:

HalleysBlue Pre Engineered Buildings contain thousands of individual components connected in systematic way with suitable grade fasteners. The overall combined & consolidated strength/stability is only achieved by proper selection of each component specific grade raw-material, welding consumable, connecting fasteners, sheeting material & other accessories.

13.1 Quality in Raw Material Selection: (Steel)

Steel Grades we use to build your building:

- ASTM A572 : Structural Steel for Main Frame.
- ASTM A607 : Secondary Framing - CR Sections.
- ASTM A307 : Foundation Anchor Bolts/Fasteners.
- ASTM A325 : High Tensile Connecting Fasteners.
- ASTM A792 : Roof & Side Sheeting.



Our complete range of raw material is being re-tested in our laboratory for required Tensile Strength & other mechanical properties before taking up for production.

13.2 Quality in Cutting Steel:

At HalleysBlue, all the Steel plates are cut in Hydraulic shearing machines rather than conventional flame cutting. This ensures every plate's mechanical properties & chemical properties are retained unaltered. This is very important parameter governing the stability.

13.3 Quality in Welding:

All the Steel Structures fabricated at HalleysBlue are welded in Fool Proof Type Automatic H Beam Sub Merged Arc welding machine ensuring 100% penetration & weld thickness.

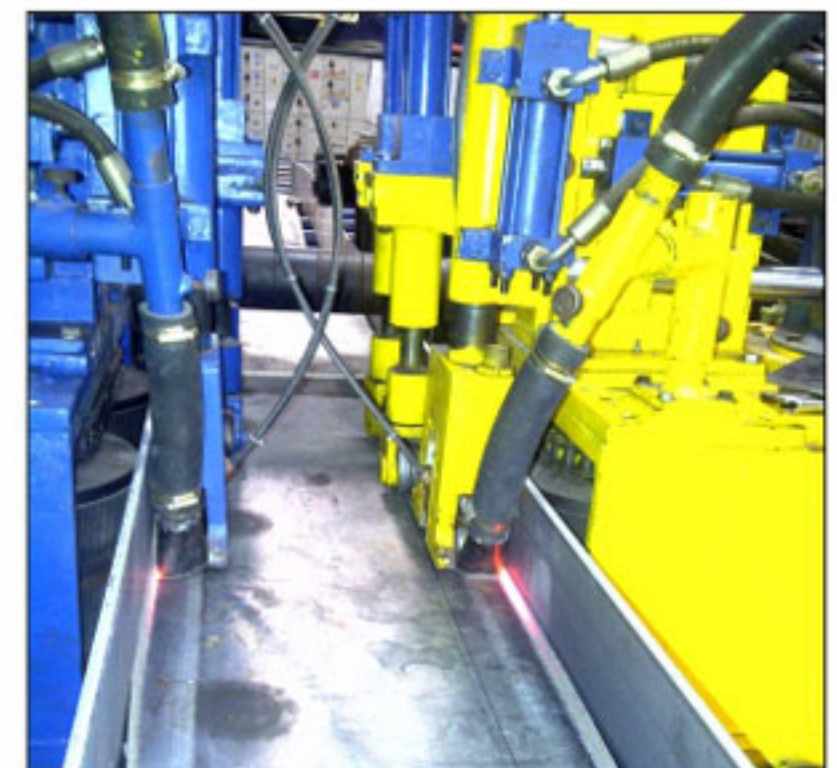

13.4 Different Welding Types:

- A) SMAW : Shielded Metal Arc Welding.
- B) SAW : Sub Merged Arc Welding.
- D) MAG/MIG : Metal Active Gas / Metal Inert Gas welding.

13.5 Our Standard Weld Tests:

- Dye Penetration Test Basic Type.
- Ultrasonic Test for Plates & Full Penetration Weld Joint.
- Magnetic Particle Testing for Fillet Weld.
- Radiography Test X-Ray Type.
- Radiography Test Gama Ray Type.
- Phased Array Ultrasonic Test (3D).



13.6 Our Standard Suppliers:



| Some of Our Projects: Industries



Coke Oven Shed, Area : 55000 Sq. ft.

Location : Koppal



Pre Cast Slab Manufacturing Unit, Area : 70000 Sq. ft.

Location : Bangalore



Distilleries & Breweries, Area : 3.0 Lakh Sq. Ft.

Location : Hassan



Glass Manufacturing Unit, Area : 1.0 Lakh Sq. Ft.

Location : Chikodi-Belgaum



Textile Industry, Area : 50000 Sq. Ft.

Location : Chitradurga





Textile Industry, Area : 45000 Sq. Ft.

Location : Byadgi





Loco Wagon Unit for Ghana Railway Department

Location : Ghana



Fertilizers Manufacturing Unit, Area : 40000 Sq. Ft.

Location : Hubli



Seed Processing Plant, Area : 50000 Sq. Ft.

Location : Ranebennur



Food Processing Plant, Area : 76000 Sq. Ft.

Location : Siruguppa





Cable Manufacturing Unit, Area : 40000 Sq. Ft.

Location : Mysore



CNC Machine Shop

Location : Mysore



Bright Bar Manufacturing Unit, Area : 23000 Sq. Ft.

Location : Hospet





Foundry Processing Unit, Area : 1.0 Lakh Sq. Ft.

Location : Belgaum



Bright Bar Manufacturing Unit, Area : 25000 Sq. Ft.

Location : Hospet



120 FEET TALL SAND PLANT



Food Processing Unit, Area : 60000 Sq. Ft.

Location : Mysore



Food Processing Unit, Area : 45000 Sq. Ft.

Location : Davanagere



Paint Processing Unit

Location : Mysore



Pump House with 50 Mt Crane Facility

Location : Chikodi - Belgaum





Carton Manufacturing Unit, Area : 30000 Sq. Ft.

Location : Mysore



Food Processing Unit, Area : 50000 Sq. Ft.

Location : Ballari



Tissue Manufacturing with Clear Span of 160'

Location : Mysore



Food Processing Unit

Location : Tumkur



Ancillary Unit for Paints, Area : 60000 Sq. Ft.

Location : Mysore



Food Processing Unit, Area :

Location : Tumkur



Food Processing Unit, Area : 25000 Sq. Ft.

Location : Karatagi



Steel Cutting Line, Area : 55000 Sq. Ft.

Location : Hubli





Logistics with 120' Clear Span at 1st Floor

Location : Mysore



Warehouse, Area : 25000 Sq. Ft.

Location : Bangalore



Warehouse

Location : Narasapur - Bangalore



Warehouse with 210' width of Building, Area : 1.5 Lakh Sq. Ft.

Location : Bangalore





Warehouse with Multigable, Area : 50000 Sq. Ft.

Location : Bangalore



Barricade Structure with 45' Height

Location : Koppal & Hiriyr



Steel Yard with 10 & 15 Mt Crane Facility

Location : Hubli



Warehouse, Area : 55000 Sq. Ft.

Location : Bangalore



Warehouse, Area : 1.0 Lakh Sq. Ft.

Location : Bangalore



Warehouse

Location : Bangalore



Warehouse

Location : Bangalore



Convention Hall with 240' clear span, Area : 85000 Sq. Ft.

Location : Hyderabad





Convention Hall, Area : 60000 Sq. Ft.

Location : Hyderabad



Convention Hall, Area : 50000 Sq. Ft.

Location : Hyderabad



Convention Hall, Area : 1.0 Lakh Sq. Ft.

Location : Hyderabad





Convention Hall, Area : 56000 Sq. Ft.

Location : Mangalore

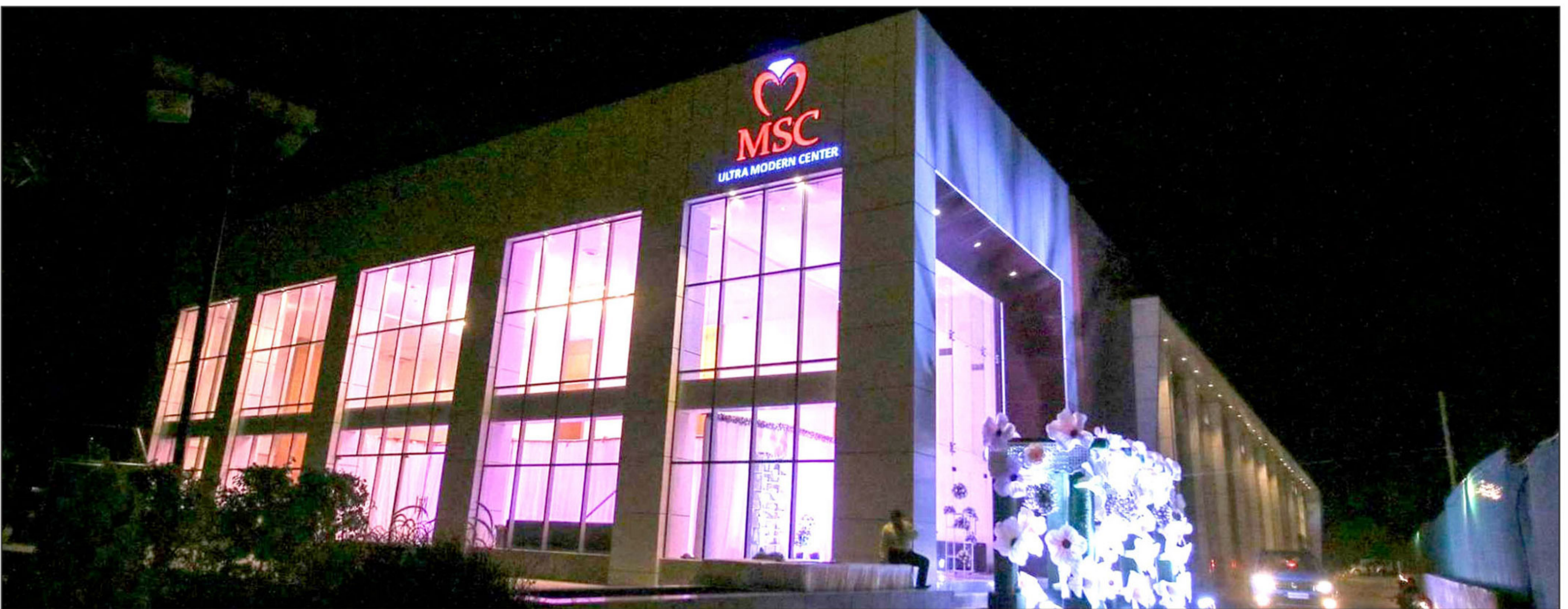

Convention Hall

Location : Hyderabad



Convention Hall, Area : 25000 Sq. Ft.

Location : Gangavathi



Convention Hall, Area : 65000 Sq. Ft.

Location : Hyderabad





Convention Hall, Area : 25000 Sq. Ft.

Location : Hyderabad

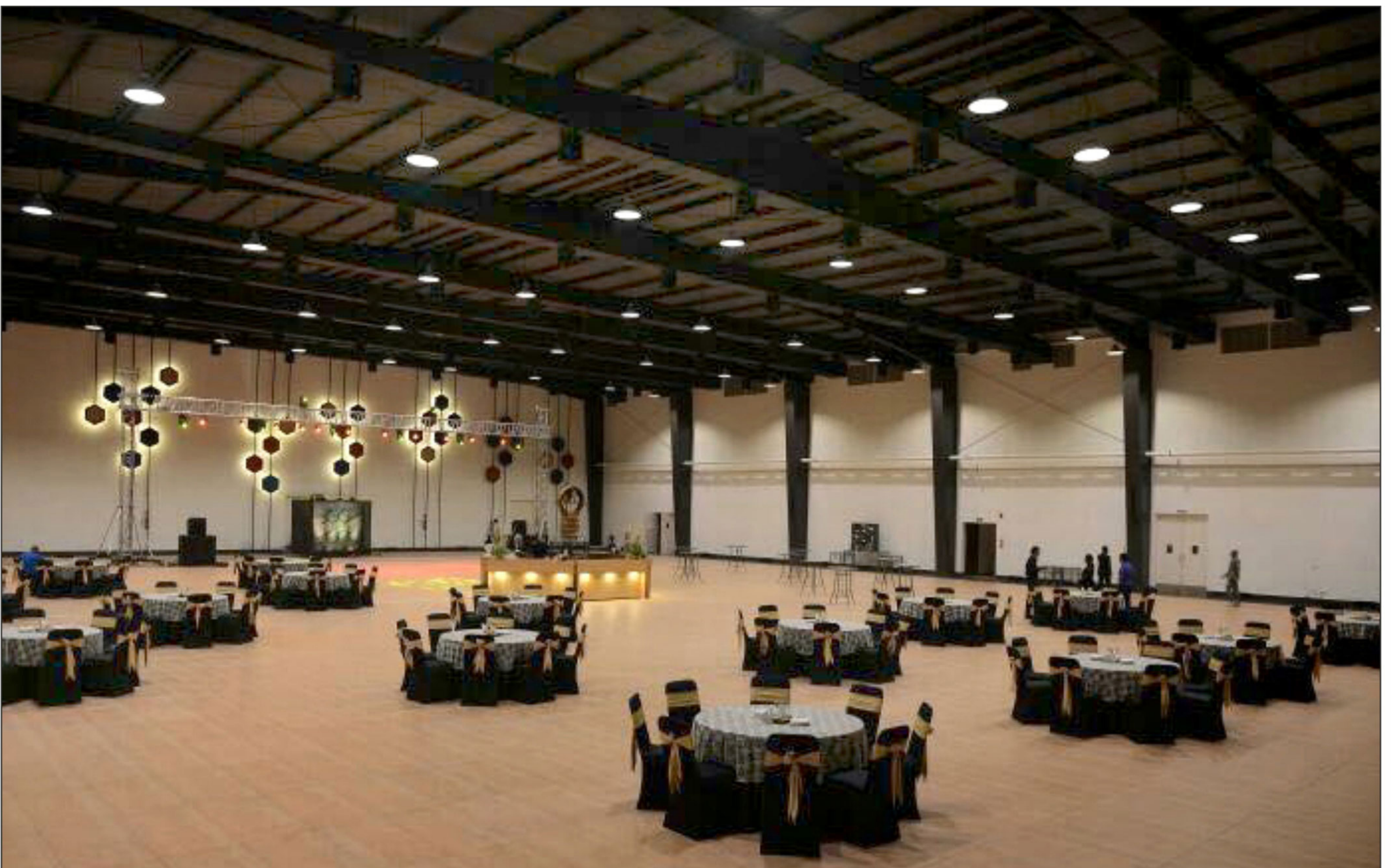



Convention Hall, Area : 80000 Sq. Ft.

Location : Hyderabad

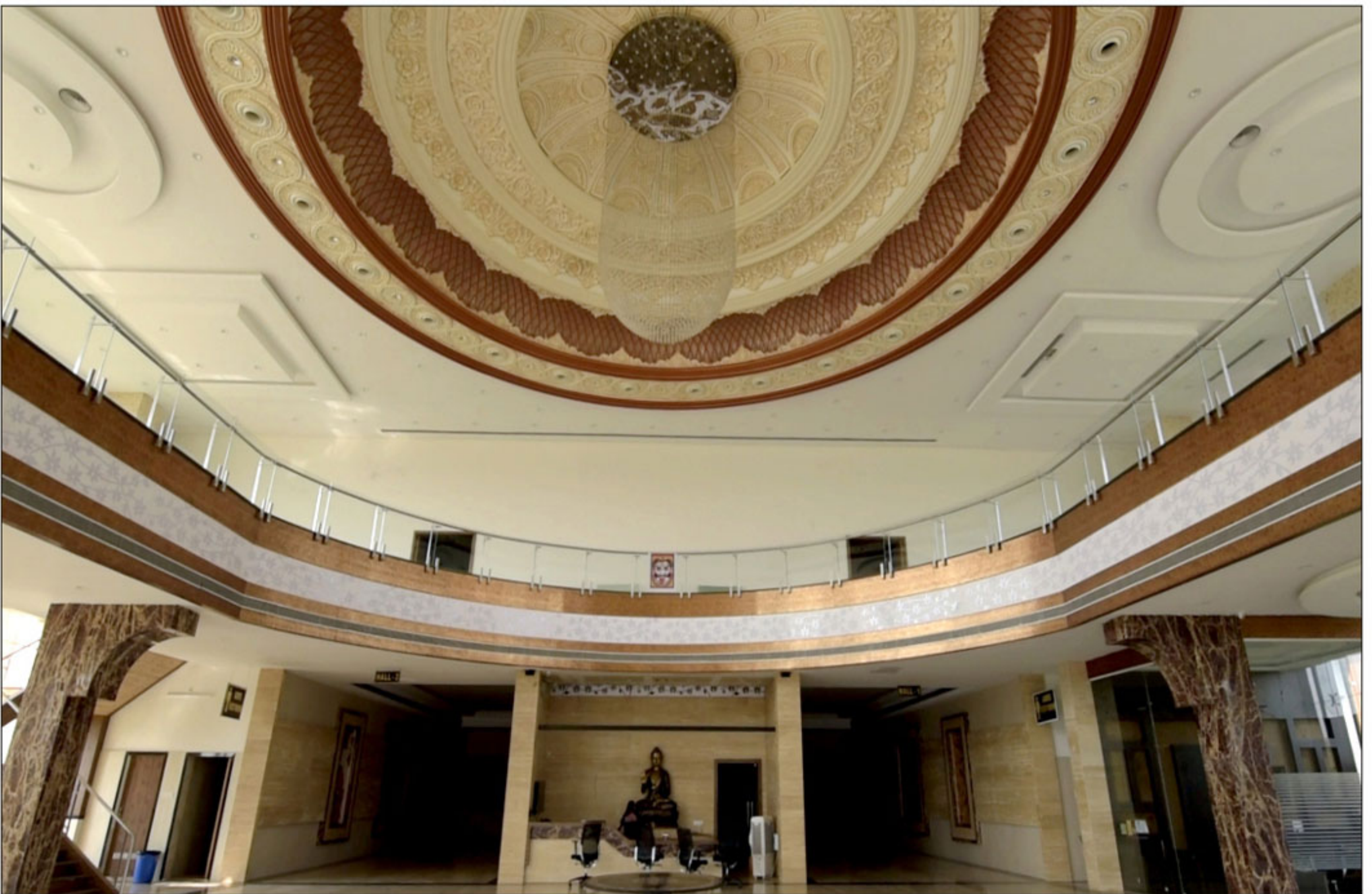





International School, Area : 75000 Sq. Ft.

Location : Bangalore





IT Office, Area : 1.5 Lakh Sq. Ft.

Location : Bangalore



Office Building

Location : Ballari

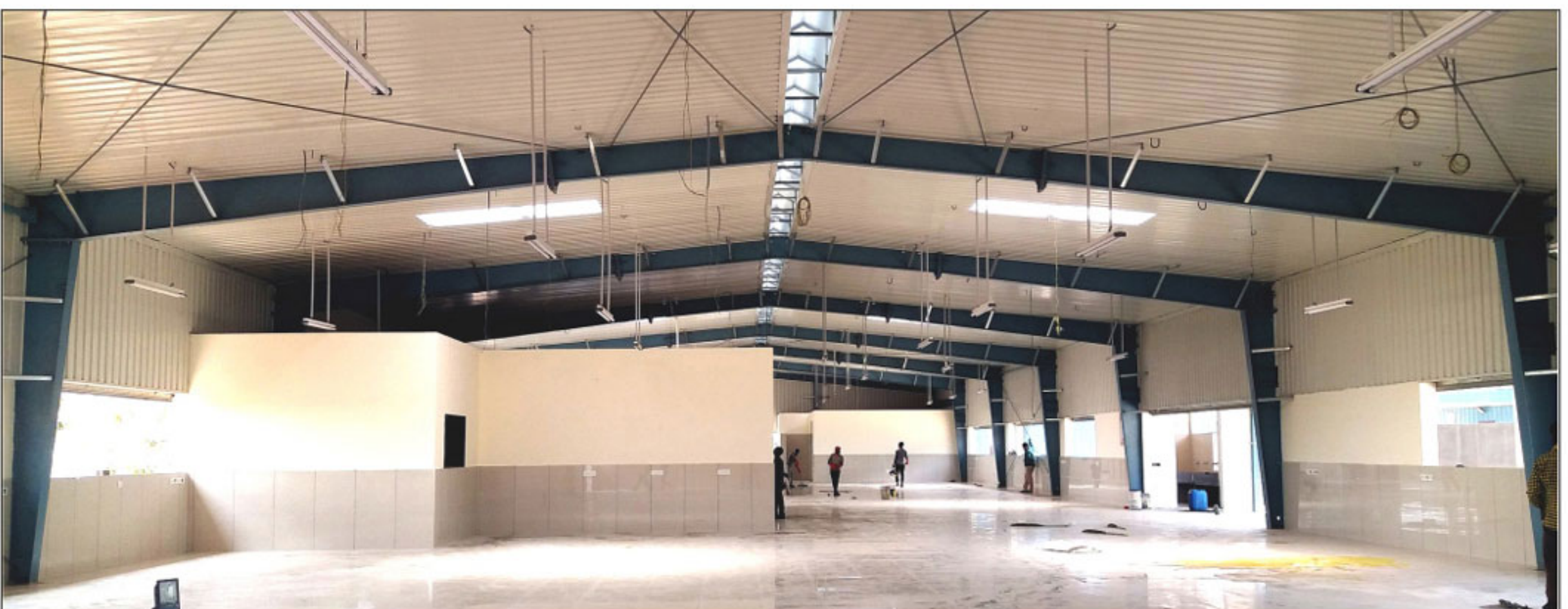

Dining Hall

Location : Belgaum



Sports Pavilion, Area : 55000 Sq. Ft.

Location : Bangalore





Showroom

Location : Hubli



Showroom

Location : Davanagere



Showroom

Location : Ballari



Showroom

Location : Hubli



Showroom

Location : Bagalkote



Showroom

Location : Ballari





Showroom

Location : Davanagere



Showroom

Location : Ballari





AFCONS INFRASTRUCTURE LIMITED
A Shapoorji Pallonji Group Company



Enriching Lives



Shamanur Sugars Ltd.





HalleysBlueTM
Built for Life

HalleysBlueTM Steels Pvt Ltd

Plant & Head Office

#57, Mundargi Industrial Area, 2nd Stage,
B'lore Road, Ballari, Karnataka, India.

T : 08392 297111

M : +91 97753 97753

E : sales@halleysblue.in

f : www.facebook.com/halleysblue

Bangalore

101, First Floor,
"Jala Aashish",
NS Iyengar Street,
Seshadripuram, Bengaluru
Karnataka - India.
Ph: +91 96060 01304

Hyderabad

306, Anish Towers,
6-1-22, Walkers Street,
Secundrabad,
Telangana - India.
Ph: +91 99725 76888.